

MIKEL'S^{MR}

Prensa Hidráulica

1 AÑO
GARANTÍA

ESTRUCTURA DE ACERO

EXTRA
REFORZADA

Soportes



Ajustables

Sistema

Doble
Bomba

MÁXIMO PODER
DE ACCIÓN



EMPAQUE



Capacidad de carga

50t

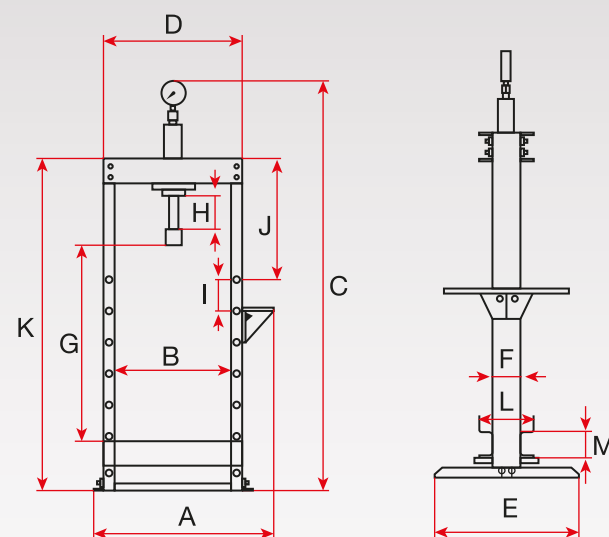

MODELO BPH-50			
A (cm)	11,45	H (cm)	23,00
B (cm)	65,00	I (cm)	16,50
C (cm)	18,30	J (cm)	63,50
D (cm)	85,00	K (cm)	160,00
E (cm)	80,00	L (cm)	32,00
F (cm)	18,00	M (cm)	18,00
G (cm)	11,45		

Rango de trabajo
0 - 86 cm

MODELO: **PHB-50**
DESCRIPCIÓN: **Prensa Hidráulica**
GARANTÍA: **1 AÑO**
PESO DOS CAJAS: **264 kg**
PIEZAS: **1 PIEZA**
EAN 13: **7501081093224**
INNER: **1 PIEZA (189 x 94 x 40)**
MASTER: **-**
DUN 14: **-**



GARANTÍA • SERVICIO • REFACCIONES

LÍNEA **AUTOMOTRIZ**

